

PROJECTOR MOTORIZED MOUNT (ALUMINIUM)

LG-APM100

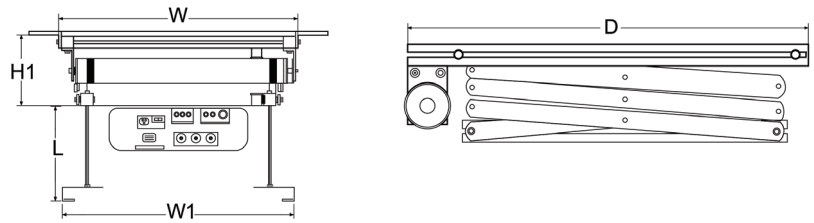

Lift Closed View

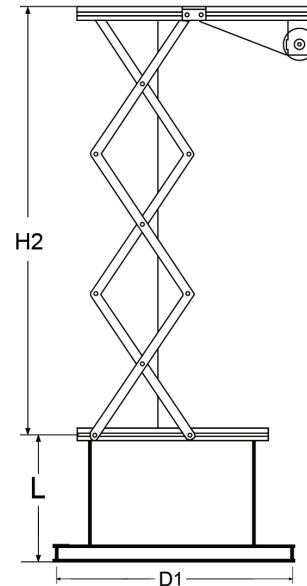

Lift Opened View

Features

- Mount extension is from 100 cm
- The product is made of Aluminium
- High quality motorization
- Quiet and smooth operation
- Maximum weight capacity is 15 kg
- Colours Available : Grey

Specification

Description	Aluminium Motorized Projector Lift 100 cm
Ceiling Depth	Min. 500 mm
Max Load	15 kg
Motor	Tubular Motor
Power Supply	220-230 V 50 Hz
Width (W)	576 mm
Depth (D)	550 mm
Bottom Plate Width (W1)	490 mm
Bottom Plate Depth (D1)	490 mm
Lift Size Closed (H1)	160 mm
Lift Size Opened (H2)	960 mm
Connecting Piece (L)	284 mm
Lift Size Opened Including Fixing (H2+L)	1244 mm
Suggested Projector Size (W x H x D)	<400 x 190 x 400 mm
Control System	RF
Product Weight	16 kg
Shipping Weight	18 kg
Shipping Dimension (L x W x H)	700 x 680 x 200 mm