

PROJECTOR MOTORIZED MOUNT (ALUMINIUM)

LG-APM150

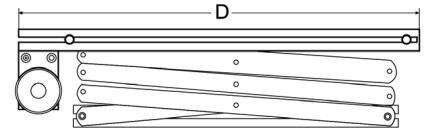

Lift Closed View

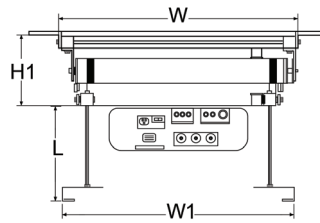
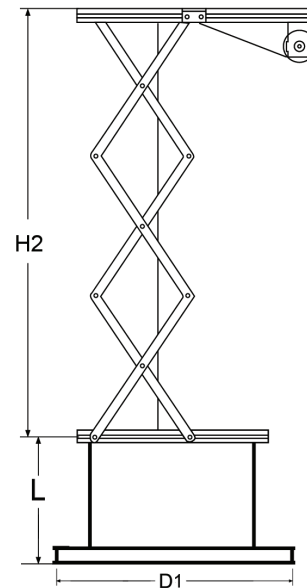

Lift Opened View

Features

- Mount extension is from 150 cm
- The product is made of Aluminium
- High quality motorization
- Quiet and smooth operation
- Maximum weight capacity is 15 kg
- Colours Available : Grey

Specification

Description	Aluminium Motorized Projector Lift 150 cm
Ceiling Depth	Min. 600 mm
Max Load	15 kg
Motor	Tubular Motor
Power Supply	220-230 V 50 Hz
Width (W)	576 mm
Depth (D)	550 mm
Bottom Plate Width (W1)	490 mm
Bottom Plate Depth (D1)	490 mm
Lift Size Closed (H1)	205 mm
Lift Size Opened (H2)	1460 mm
Connecting Piece (L)	284 mm
Lift Size Opened Including Fixing (H2 + L)	1744 mm
Suggested Projector Size (W x H x D)	<400 x 190 x 400 mm
Control System	RF
Product Weight	17 kg
Shipping Weight	19 kg
Shipping Dimension (L x W x H)	700 x 680 x 200 mm