

PROJECTOR MOTORIZED MOUNT (ALUMINIUM)

LG-APM200

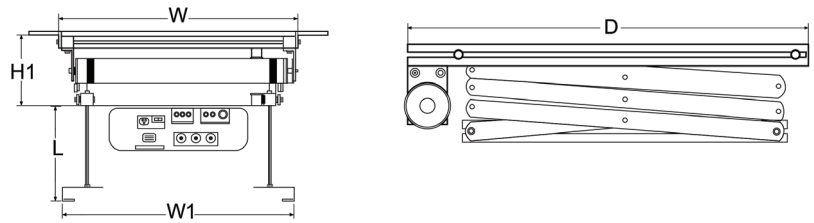

Lift Closed View

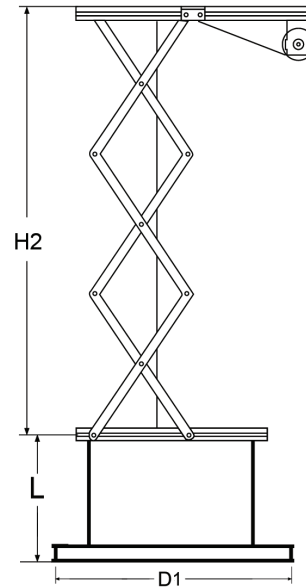

Lift Opened View

Features

- Mount extension is from 200 cm
- The product is made of Aluminium
- High quality motorization
- Quiet and smooth operation
- Maximum weight capacity is 15 kg
- Colours Available : Grey

Specification

Description	Aluminium Motorized Projector Lift 200 cm
Ceiling Depth	Min. 800 mm
Max Load	15 kg
Motor	Tubular Motor
Power Supply	220-230 V 50 Hz
Width (W)	576 mm
Depth (D)	550 mm
Bottom Plate Width (W1)	490 mm
Bottom Plate Depth (D1)	490 mm
Lift Size Closed (H1)	235 mm
Lift Size Opened (H2)	1960 mm
Connecting Piece (L)	284 mm
Lift Size Opened Including Fixing (H2 + L)	2244 mm
Suggested Projector Size (W x H x D)	<400 x 190 x 400 mm
Control System	RF
Product Weight	18 kg
Shipping Weight	20 kg
Shipping Dimension (L x W x H)	700 x 680 x 200 mm