

## PROJECTOR MOTORIZED MOUNT (ALUMINIUM)

### LG-APM300

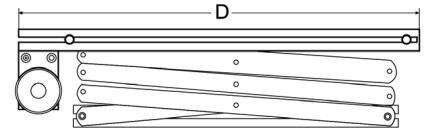

Lift Closed View

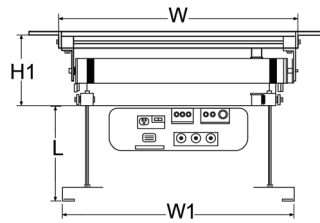
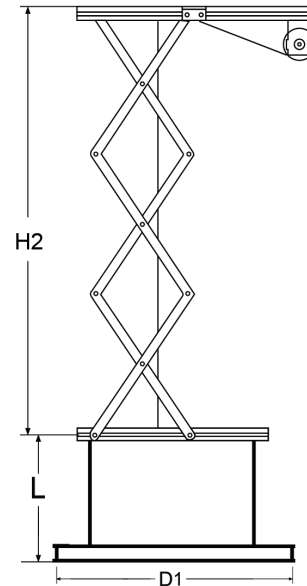

Lift Opened View

### Features

- Mount extension is from 300 cm
- The product is made of Aluminium
- High quality motorization
- Quiet and smooth operation
- Maximum weight capacity is 15 kg
- Colours Available : Grey

### Specification

Description	Aluminium Motorized Projector Lift 300 cm
Ceiling Depth	Min. 1000 mm
Max Load	15 kg
Motor	Tubular Motor
Power Supply	220-230 V 50 Hz
Width (W)	576 mm
Depth (D)	550 mm
Bottom Plate Width (W1)	490 mm
Bottom Plate Depth (D1)	490 mm
Lift Size Closed (H1)	305 mm
Lift Size Opened (H2)	2960 mm
Connecting Piece (L)	284 mm
Lift Size Opened Including Fixing (H2 + L)	3244 mm
Suggested Projector Size (W x H x D)	<400 x 190 x 400 mm
Control System	RF
Product Weight	21 kg
Shipping Weight	23 kg
Shipping Dimension (L x W x H)	700 x 690 x 340 mm