

## MOTORIZED WALL MOUNT BRACKET- VERTICAL

HEIGHT ADJUSTABLE : LGWM-6586VH-M-N22

EQUIPMENT RACK : ER-03 (OPTIONAL ACCESSORIES)

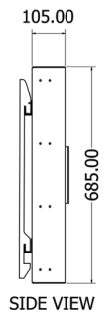
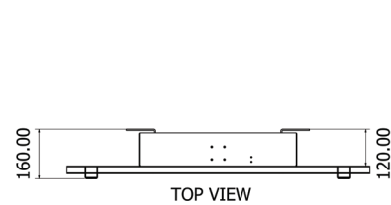
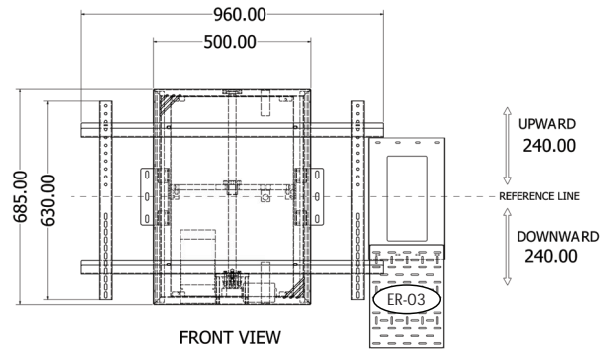

### Features

- Universal in design to fit 65" to 86" displays
- The display mount can hold weight up to 60 kg
- Height adjustment facility for displays (Interactive Panels)
- 210 mm of stroke length upwards and downwards from the reference line
- Clutter-free performance with less noise
- Remote for comfortable operation
- Quick and easy installation
- VESA compliant
- Colours available – Black

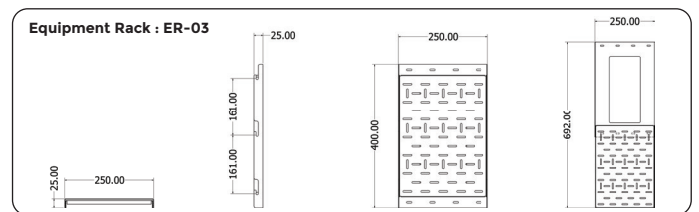

### Specification

Model Number	LGWM-6586VH-M-N22	ER-03
Max. Load	: 132.25 lbs (60 kg)	22 lbs (10 kg)
VESA	: 400 x 400 to 900 x 600	-
Display Sizes	: 65" to 86"	65" to 86"
Material	: Steel	-
Stroke Length	: 210 mm (↑↓)	-
Product Weight	: 32 kg	2.1 kg
Shipping Weight	: 35 kg	-

\*Dimensions in mm