

## LM-305-N19

### MANUAL SERIES



### Features

- LM-305-N19 is a compact cable manager solution designed for installation into a table as part of a presentation system.
- The product can be mounted into a table and podium to provide a way to connect audio visual equipments.
- Soft opening with comfort and safety.
- Equipped with Flip open cover system.
- The product is made up of steel and aluminium.
- Product Weight : 1.5 kg
- Shipping Weight : 1.8 kg
- Shipping Dimension : 180 x 180 x 200 mm (L x W x H)
- Colour available : Black

### Connectivity

1 x Universal Power
1 x USB-A Mobile Charger
1 x HDMI 2.0V
1 x CAT 6A RJ-45 Network
1 x 3.5 mm Audio
1 x VGA

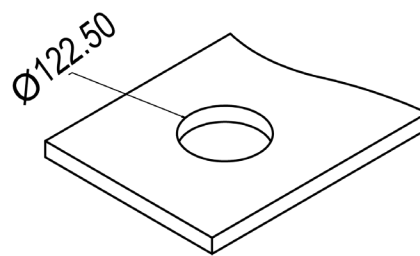
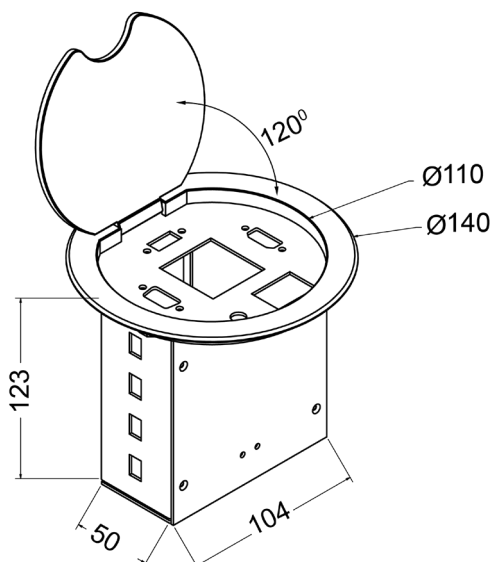

Table Cutout

\*Dimensions in mm